

# DCT-3A

Digital to Analog Audio Converter



Operation Manual



## **DISCLAIMERS**

The information in this manual has been carefully checked and is believed to be accurate. Cypress Technology assumes no responsibility for any infringements of patents or other rights of third parties which may result from its use.

Cypress Technology assumes no responsibility for any inaccuracies that may be contained in this document. Cypress also makes no commitment to update or to keep current the information contained in this document.

Cypress Technology reserves the right to make improvements to this document and/or product at any time and without notice.

## **COPYRIGHT NOTICE**

No part of this document may be reproduced, transmitted, transcribed, stored in a retrieval system, or any of its part translated into any language or computer file, in any form or by any means—electronic, mechanical, magnetic, optical, chemical, manual, or otherwise—without express written permission and consent from Cypress Technology.

© Copyright 2011 by Cypress Technology.

All Rights Reserved.

Version 1.1 August 2011

## **TRADEMARK ACKNOWLEDGMENTS**

All products or service names mentioned in this document may be trademarks of the companies with which they are associated.





## SAFETY PRECAUTIONS

Please read all instructions before attempting to unpack, install or operate this equipment and before connecting the power supply.

Please keep the following in mind as you unpack and install this equipment:

- Always follow basic safety precautions to reduce the risk of fire, electrical shock and injury to persons.
- To prevent fire or shock hazard, do not expose the unit to rain, moisture or install this product near water.
- Never spill liquid of any kind on or into this product.
- Never push an object of any kind into this product through any openings or empty slots in the unit, as you may damage parts inside the unit.
- Do not attach the power supply cabling to building surfaces.
- Use only the supplied power supply unit (PSU). Do not use the PSU if it is damaged.
- Do not allow anything to rest on the power cabling or allow any weight to be placed upon it or any person walk on it.
- To protect the unit from overheating, do not block any vents or openings in the unit housing that provide ventilation and allow for sufficient space for air to circulate around the unit.

## REVISION HISTORY

VERSION NO.	DATE DD/MM/YY	SUMMARY OF CHANGE
VS1	11/12/12	First Release



# CONTENTS

- 1. Introduction..... 1**
- 2. Applications..... 1**
- 3. Package Contents ..... 1**
- 4. System Requirements..... 1**
- 5. Features ..... 1**
- 6. Operation Controls and Functions..... 2**
  - 6.1 Front Panel .....2
  - 6.2 Right Panel.....2
  - 6.3 Left Panel .....3
  - 6.4 Top Panel .....3
- 7. Connection Diagram ..... 4**
- 8. Specifications ..... 5**
- 9. Acronyms ..... 5**





## 1. INTRODUCTION

The Digital to Analog Audio Converter is an easy to use product that converts Coaxial or Optical audio signals into analog Stereo (R/L) audio. It can be easily switched between either Coaxial or Optical inputs. With its compact, elegant design and simple LED input status make it easier for users to connect up and use instantly.

## 2. APPLICATIONS

- HDTV digital output conversion
- 24-bit DAC conversion

## 3. PACKAGE CONTENTS

- Digital to Analog Audio Converter
- 5 V/1 A DC Power Adaptor
- Operation Manual

## 4. SYSTEM REQUIREMENTS

Source equipment such as a DVD/Blu-ray player or an HDTV and output to active speaker or amplifier with connection cables.

## 5. FEATURES

- Supports digital audio input (Coaxial/Optical) and stereo analog audio output (R/L)
- Integrated digital interpolator filter and Digital to Analog Converter (DAC)
- Supports uncompressed digital stereo audio input
- Compact size and easy to install
- Supports S/PDIF 192 kHz at 24-bit data for conversion to left and right analog channels

## 6. OPERATION CONTROLS AND FUNCTIONS

### 6.1 Front Panel

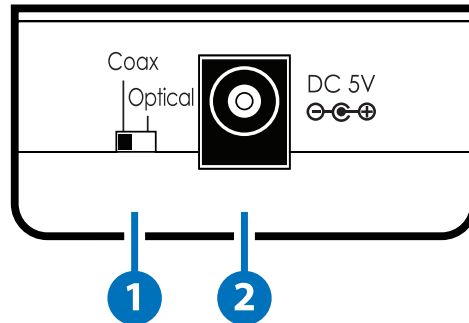

- 1 **Coaxial/Optical Switch:** Select which digital audio input is active and will be converted to analog stereo (R/L) audio.
- 2 **DC 5V:** Connect the 5V DC power supply to the unit and plug the adaptor into an AC wall outlet.

### 6.2 Right Panel

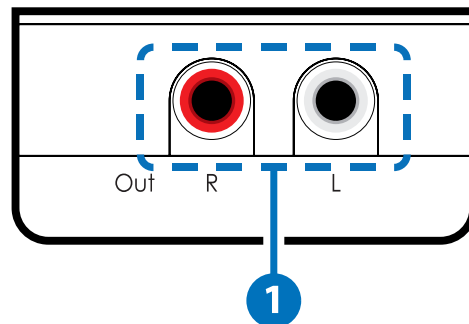

- 1 **R/L Out:** Analog stereo output. Connect to the input of your audio device or display.

## 6.3 Left Panel

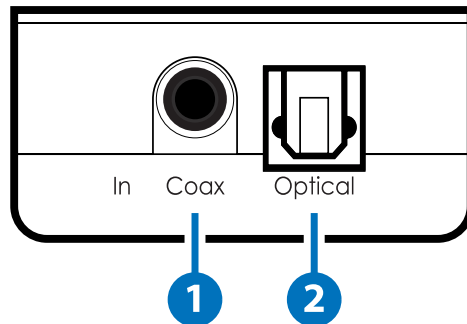

- 1 Coaxial In:** Connect to the Coaxial digital audio source, such as a DVD player or CD player.
- 2 Optical In:** Connect to the Optical audio source, such as a Blu-ray player or games console.

## 6.4 Top Panel

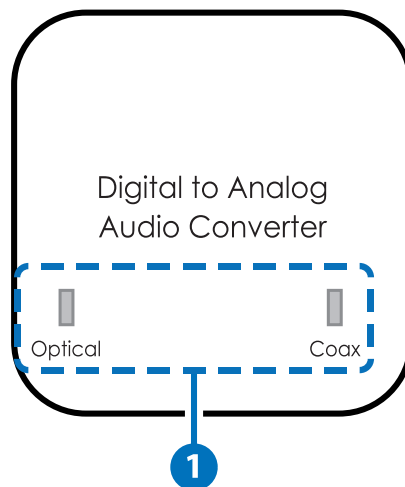

- 1 Coaxial/Optical Input Status LED:** The LED light will illuminate according to which input is currently selected.



## 7. CONNECTION DIAGRAM

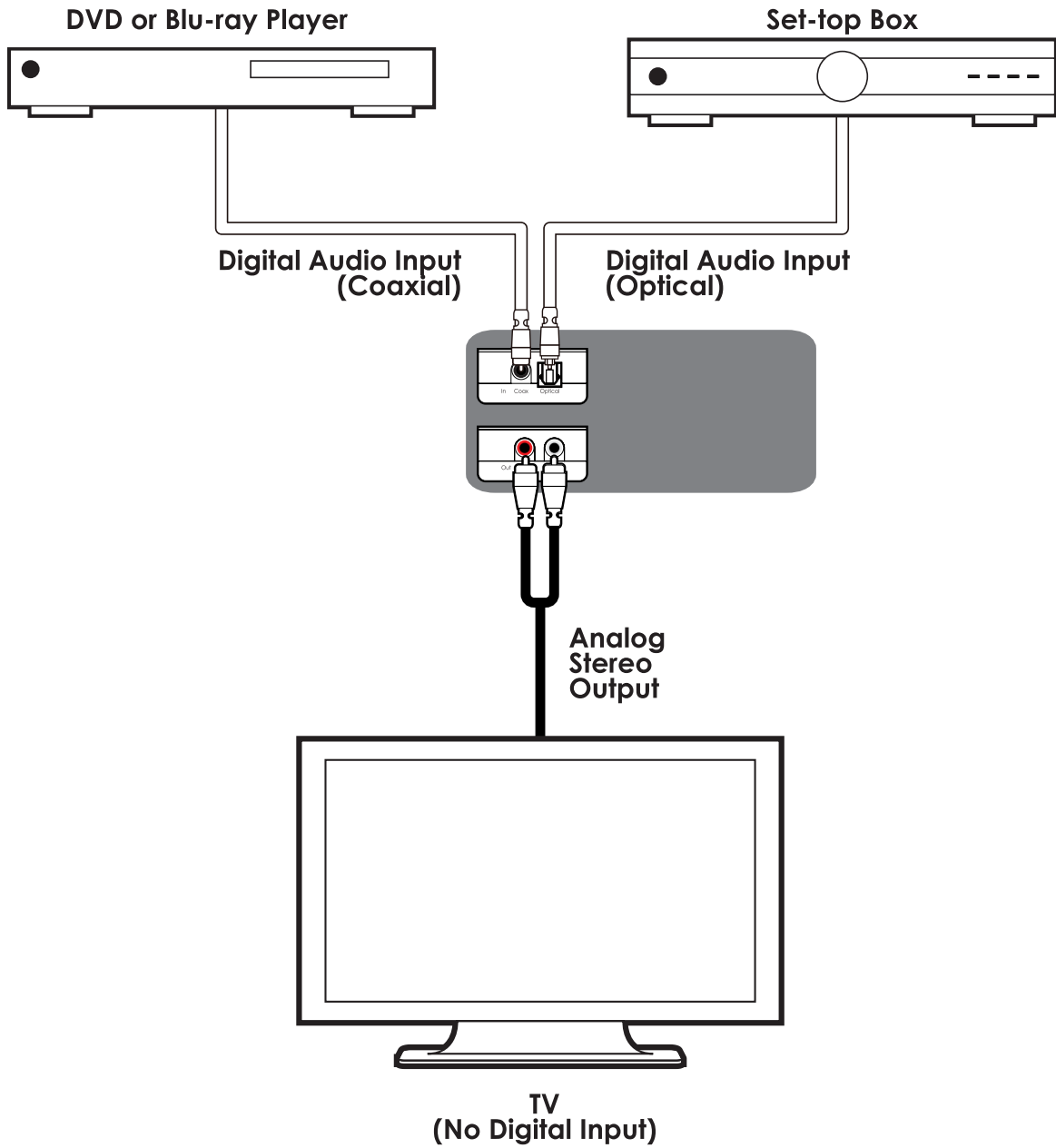



## 8. SPECIFICATIONS

<b>Input Ports</b>	1×Coaxial, 1×Optical
<b>Input Format</b>	S/PDIF LPCM 2 CH, 24-bit
<b>Input Sampling Rate</b>	32 kHz, 44.1 kHz, 48 kHz, 88.2 kHz, 96 kHz, 176.4 kHz up to 192 kHz
<b>Output Ports</b>	Analog Stereo (R/L)
<b>Output Level</b>	2 Vrms
<b>Output Impedance</b>	600 Ω
<b>Power Supply</b>	5 V/1 A DC linear power adaptor (US/EU standards, CE/FCC/UL certified) or 5 V/1.2 A switching power adaptor (with universal plug. CE/FCC/UL certified)
<b>Dimensions</b>	42mm (W)×40.5 mm (D)×22 mm (H)
<b>Weight</b>	25 g
<b>Chassis Material</b>	Plastic
<b>Silkscreen Color</b>	White
<b>Operating Temperature</b>	0 °C~40 °C
<b>Power Consumption</b>	0.74 W

## 9. ACRONYMS

ACRONYM	COMPLETE TERM
DAC	Digital to Analog Converter
S/PDIF	Sony/Philips Digital Interconnect Format





**CYPRESS TECHNOLOGY CO., LTD**

Home page: <http://www.cypress.com.tw>

20121211 MPM-DCT3A